

EVB-USB2524QFN

Eval Board for USB2524QFN, QFN56 package

Revision History

Revision	Date	Revision Summary	Author
A	20051214	Initial schematic based on SVB-USB2524QFN-SKT, Rev. A.	C. Johnson
A.01	20060118	Revised notes @ J16, J22, and J1	C. Johnson
B	20060519	Simplified LED options, removed LED and P.Pwr headers, replaced SIP switch, added auto-switch function, replaced GN/YL LEDs with GN/RD, added Gryphics socket option.	C. Johnson
B1	20060607	Revised Port Assign sequencing timing circuit.	C. Johnson

 SMSC [™] SUCCESS BY DESIGN		11000 N. Mopac Expressway Stonelake Building 6, Suite 500 Austin, TX 78759-5428 512.502.0070
Title EVB-USB2524QFN - USB2524, 56 pin QFN package, User Evaluation Platform		
Size C	Document Number EVB-USB2524QFN (CrenshawQFN)	Rev B1
Date: Wednesday, June 07, 2006 Sheet 1 of 2		

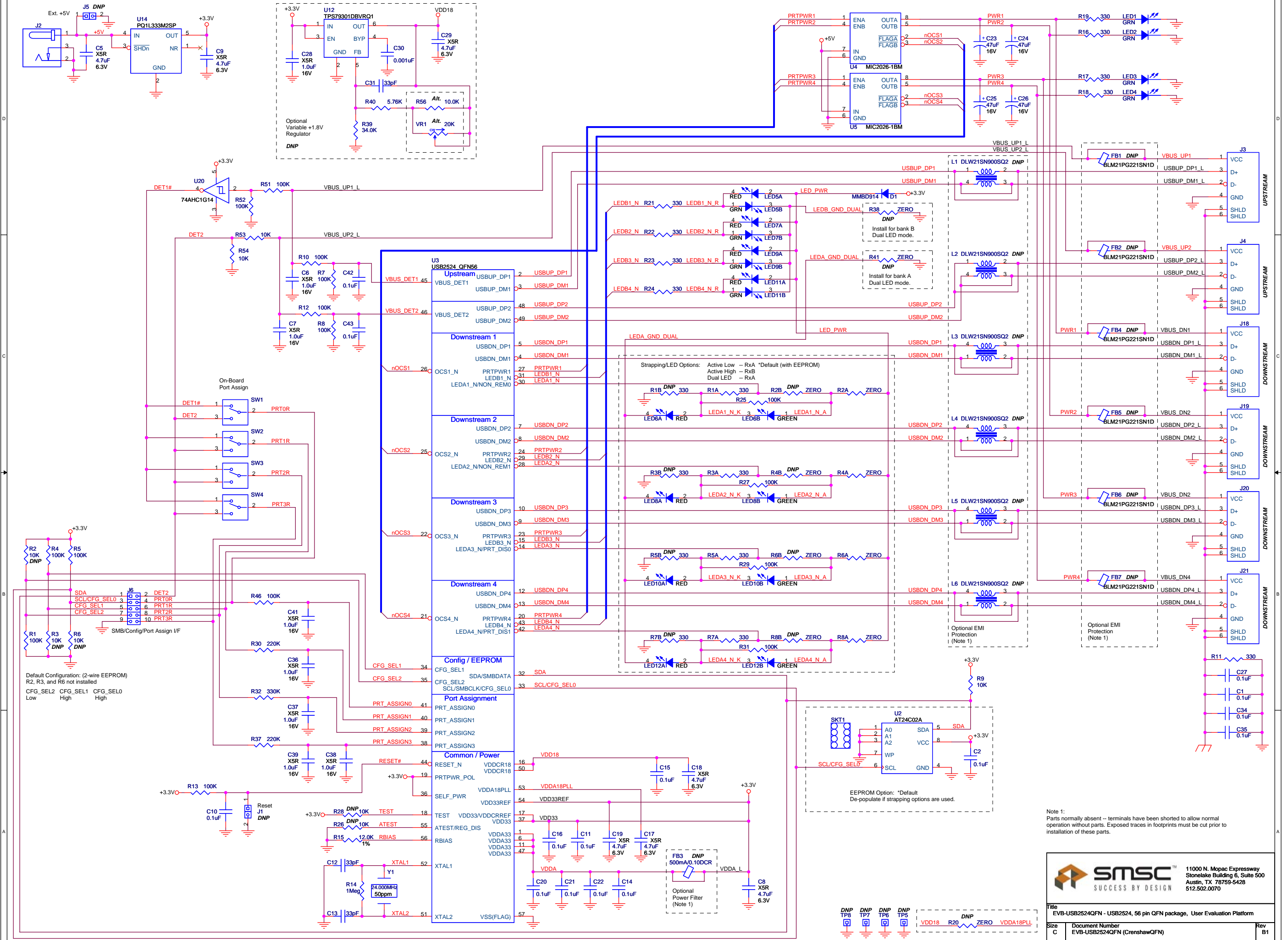

D

C

B

A

D

C

B

A

Note 1:
Parts normally absent -- terminals have been shorted to allow normal operation without parts. Exposed traces in footprints must be cut prior to installation of these parts.

Title		EVB-USB2524QFN - USB2524, 56 pin QFN package, User Evaluation Platform	
Size	Document Number	Rev	
C	EVB-USB2524QFN (CrenshawQFN)	B1	
Date:	Wednesday, June 21, 2006	Sheet	2 of 2