



Application Note

High Resolution Digital Weigh-Scale Design Using Z8 Encore!® Microcontrollers

AN025401-1206



Abstract

This application note describes the development and use of a Digital Weigh-Scale (DWS) using ZiLOG's Z8 Encore!® microcontroller. This reference design offers a ready-to-use DWS solution easily scalable to measure high-capacity loads. A high-resolution Analog-to-Digital Converter (ADC) external to the microcontroller is used to accurately measure the load cell output. The measured weight is displayed on the LCD.

► **Note:** The source code associated with this reference design is available under *Z8 Encore! Applications Code Library* in Application Sample Libraries on www.zilog.com.

Features

The main features of DWS are:

- Measures 10 g to 40 kg (with 10 g resolution)
- TARE feature to measure net weight
- Count items with identical weights
- Calibration of weigh-scale
- Selectable clock source and reference voltage for ADC
- Displays weight on single-line 8 character (8 x 1) LCD (see [Figure 1](#))

Discussion

Digital Weigh-Scale measures weight or change in weight depending on the object for measurement. It displays weight in digital format with appropriate units of weight. Load cells whose output voltage changes proportionally to the weight applied are the most commonly employed measuring components.

The low voltage output of a load cell which is in the order of few millivolts needs to be amplified and digitized. This requires an ADC with a resolution greater than 16-bit.

A high-resolution ADC with a built-in amplifier is used for these type of applications. The ADC output is read by a microcontroller and appropriate algorithms are used to calculate the weight and display them.

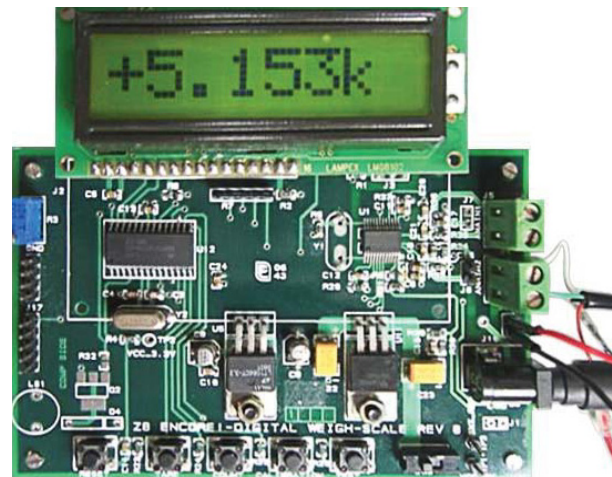

Figure 1. Digital Weigh-Scale Reference Design Board

Hardware Architecture

This reference design is based on the Z8 Encore! MCU which communicates with the 24-bit ADC CS5550 through Serial Peripheral Interface (SPI). The output voltage of the load cell is passed through a Low-Pass Filter (LPF) to suppress any high frequency noise and applied to ADC. The measured weight is displayed on a 8 x 1 LCD. This design supports the user interface to handle TARE, COUNT, and CALIBRATION modes of weigh-scale operation. The power supply for DWS is



derived from a 9 V DC adapter. It is essential that the excitation voltage for the load cell and the ADC reference voltage is derived from the same source to provide ratiometric connection. Hence, any variation in excitation voltage of the load cell does not result in loss of measurement accuracy, since the ADC's voltage resolution changes proportionally.

The block diagram in Figure 2 provides an overview of the DWS hardware architecture. For more details on hardware connections, see Appendix A—Schematics.

► **Note:** The analog input pin, AIN2, is used as the default analog channel for measurements. The AIN1 pin is used to measure much lower load cell voltages as it supports higher gain.

Switch Functionalities

The functionalities of different switches used in the design are described further.

TARE

TARE is a term used in weights and measurements which refers to the weight to be subtracted from the gross-weight in order to obtain the net weight. For example, to measure the weight of contents in a container, the weight of container (TARE) is subtracted from the gross weight (weight of container + weight of contents). For more details on usage, see ‘Using TARE Function’ and for software implementation, see Figure 7.

COUNT

The COUNT switch is used to determine counts of a known weight item. For more details on usage, see ‘Using COUNT Function’ and for software implementation, see Figure 8.

CALIBRATION (External ADC)

The CALIBRATION switch allows you to perform gain and offset calibration on external ADC CS5550.

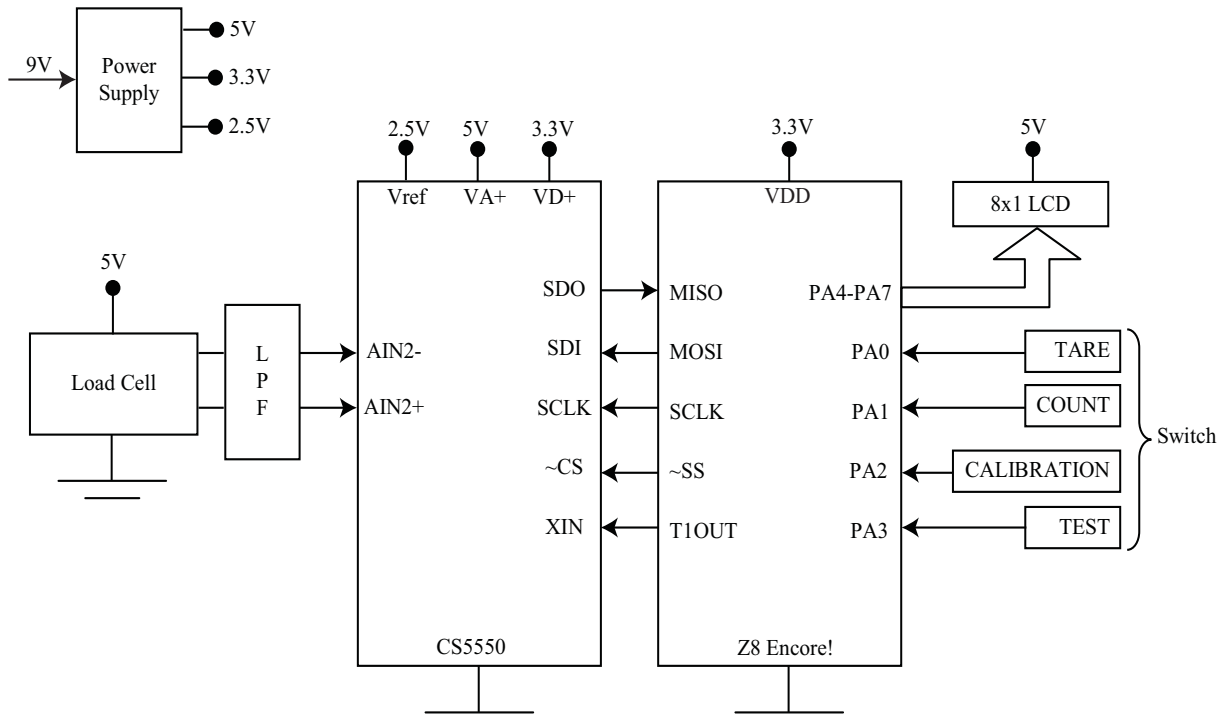

Figure 2. Digital Weigh-Scale Hardware Block Diagram

TEST

The TEST switch allows you to come out of TARE and COUNT modes and display the absolute weight placed on the load cell.

Software Implementation

This reference design makes use of the Z8 Encore!'s on-chip SPI, Timer, and GPIO peripheral. The software presented with this application initializes these peripherals and configures the CS5550 ADC. The output of Timer1 is used as system clock source for CS5550. The output of CS5550 is read every 50 ms. Timer0 is configured to generate interrupt every 1 ms. A flag indicating the 50 ms timeout is monitored and initially 10 samples of ADC output are collected and stored into a buffer. The average of these 10 samples is used to calculate the weight. Each new sample collected thereon replaces the oldest sample in the buffer. If the current ADC value differs from its previous value by a predefined threshold, then, it implies that there is a substantial change in weight and 10 new samples are collected. This way, sudden weight changes are taken into account. The threshold ADC value is selectable through THRESHOLD_WEIGHT_DIFFERENCE macro. All weight, COUNT value, and operating modes of weigh-scale are displayed on LCD. Weight less than 1 kg is displayed in grams. Weight greater than 999 g is displayed in kilograms with 3 decimal places. The software also continuously polls switch press and corresponding functionalities of the switches are performed. See [Appendix B—Flowcharts](#) of the software functioning.

As the ADC count value read from the controller corresponds to the Load cell output, the Load cell characteristic is derived by plotting ADC count values against standard weights. An appropriate equation is obtained from this plot which is used to calculate the weight at run-time. [Figure 3](#) illustrates the characteristic of the load cell used in this reference design.

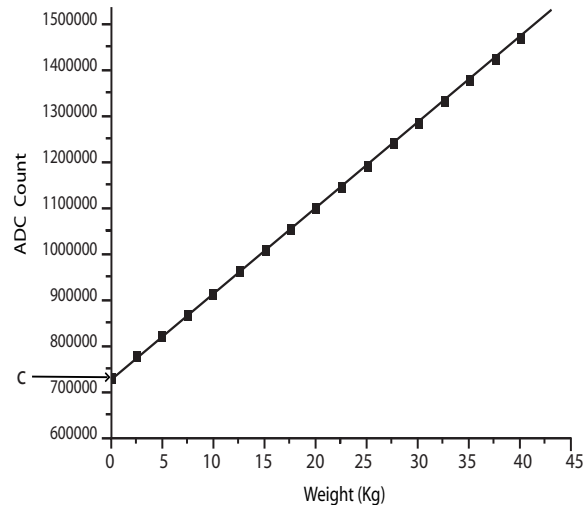

Figure 3. Load Cell Characteristics

[Figure 3](#) plot results in a linear equation of type

$$y = mx + c \quad (1)$$

where,

- x is the weight in kilograms
- y is the ADC Count corresponding to the applied weight
- c is the ADC Count when no load is present on load cell
- m is the slope of the curve

Rearranging [Equation \(1\)](#),

$$x = (y - c)/m \quad (2)$$

[Equation \(2\)](#) is used to calculate weight at runtime. As the load cell characteristic varies from one to another, you have to derive an appropriate equation as discussed above and calculate the weight.

Performing Weight Measurements

Setup

Setup for measuring weight is provided below:

1. Connect the bridge excitation terminals of the load cell to connector J16 on the reference design board.



2. Connect the differential output of the load cell to connector J4.
3. Plug in a 9 V, 10 W DC adapter to J15.
4. Put the SPDT switch SW6 in ON position to power up the board.
5. Build `digital_weigh_scale.zdsproj` available in the source folder of the Application Library using ZDSII—Z8 Encore!.
6. Download the code onto the reference board.

Basic Weight Measurement

The procedure for measuring basic weight is provided below:

1. Execute the code and observe the measured weight on LCD. This value will vary from one load cell to other. You will have to calibrate the weigh-scale against standard weights to get accurate readings.
2. Place some weight on the load cell and the measured weight will be displayed on the LCD screen.

Using TARE Function

The procedure for TARE function is provided below:

1. Place the object on the scale whose weight is to be offset for further measurements.
2. Press TARE switch. Character ‘T’ is displayed on the LCD indicating that the scale is in TARE mode.
3. Place the object whose weight is to be measured on the load cell.
4. To come out of TARE mode and start absolute measurement, press the TEST switch.

Using COUNT Function

The procedure for using the COUNT function is provided below:

1. Place the reference weight on load cell against which the counting is to be done and press COUNT switch.

2. The LCD displays count value ‘1’ and the mode ‘C’ indicating that the scale is in COUNT mode.
3. Place additional identical weights to view the number of objects kept on the load cell.
4. To come out of COUNT mode and start weight measurement, press the TEST switch.

Using CALIBRATION Function

The procedure for using the CALIBRATION function is provided below:

1. Press the CALIBRATION switch. LCD will display ‘OFFSET’. At this point connect the ‘+’ and ‘-’ pins of J4 (for AIN2) to ground and press the CALIBRATION switch again.
2. The LCD will display ‘GAIN’. Connect the load cell output to J4 (for AIN2) channels and put maximum weight to be measured on the load cell. This maximum weight applies the absolute maximum instantaneous voltage to be measured across the analog inputs.
3. Press the CALIBRATION switch again to complete gain calibration.

Optional Design Changes

The optional design changes which can be implemented are as follows:

1. To change the system clock source to an external crystal for CS5550, populate crystal Y1 and do not use resistor R5.
2. To use internal reference voltage for CS5550, populate the resistor R6 and do not populate resistor R31.

► **Note:** By default, the reference design uses external reference voltage for CS5550 on-chip modulator and Timer1 output as the system clock source.



Summary

The reference design based on Z8 Encore! Z8F0812 MCU provides a scalable and ready-to-use solution for DWS. The software is modular and easy to customize for any weight measurement application.

For lower resolution, the design can be based on Z8F0822, which has 10 bit on-chip ADC. This would necessitate the use of external amplifier to boost the load cell output. The reference design can be easily ported to Z8F1680 for low-cost and low-power solution.

References

The documents associated with Z8 Encore! Z8F0812 MCU available on www.zilog.com are provided below:

- Product Specification—Z8 Encore![®] 8K Series (PS0225)
- eZ8 CPU User Manual (UM0128)
- Product Specification—CS5550 (CS5550_F1) available on www.cirrus.com



Appendix A—Schematics

Appendix A illustrates the schematics of Digital Weigh-Scale reference board.

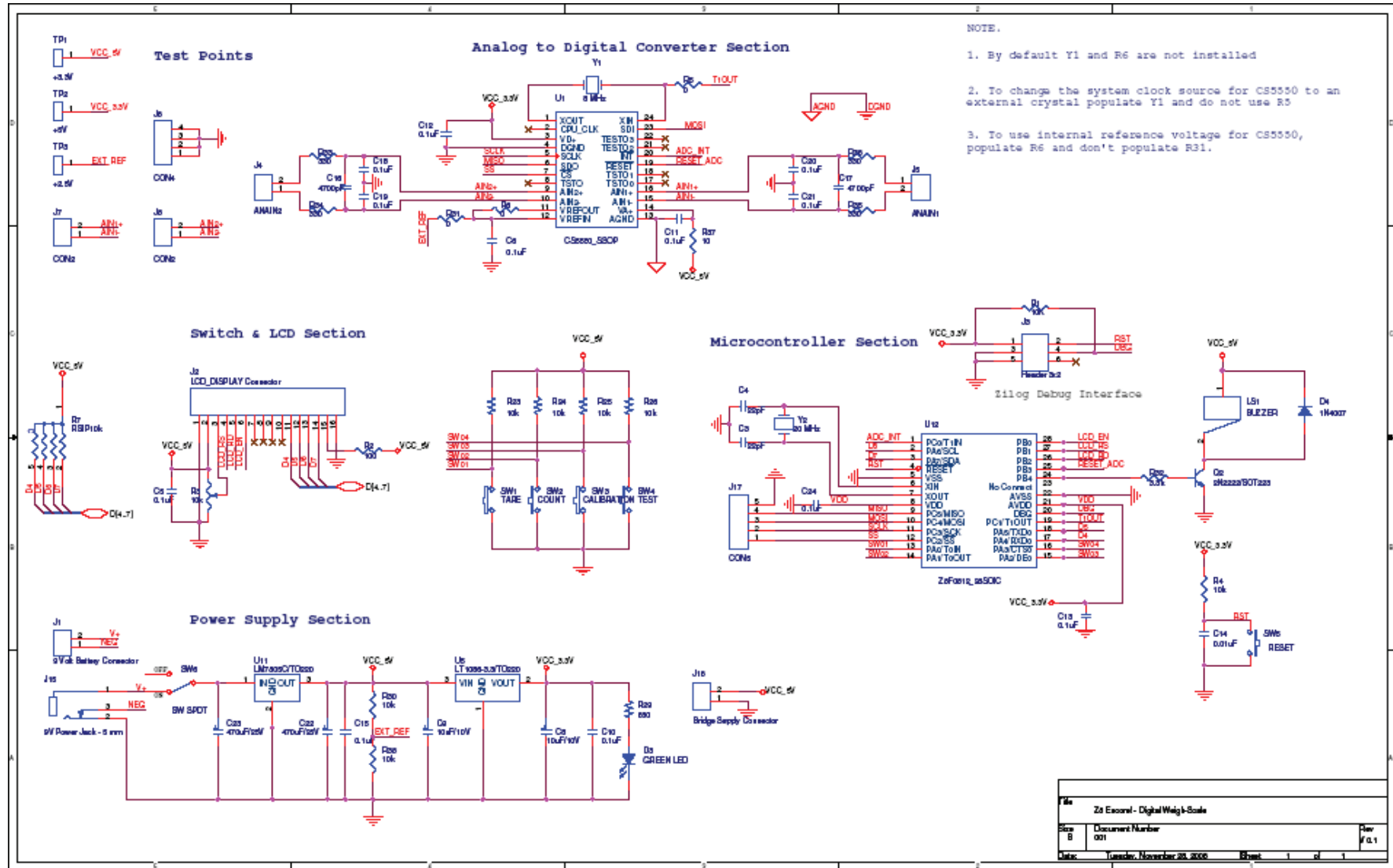



Appendix B—Flowcharts

This Appendix displays the flowcharts of Main Function, ADC Sample Collection and Change in Weight Detection Routine, Weight Calculation Routine,

TARE Switch Handling Function, COUNT Switch Handling Function, CALIBRATION Switch Handling Function, and Processing Switch Inputs in the application of Digital Weigh-Scale Using Z8 Encore! Microcontrollers.

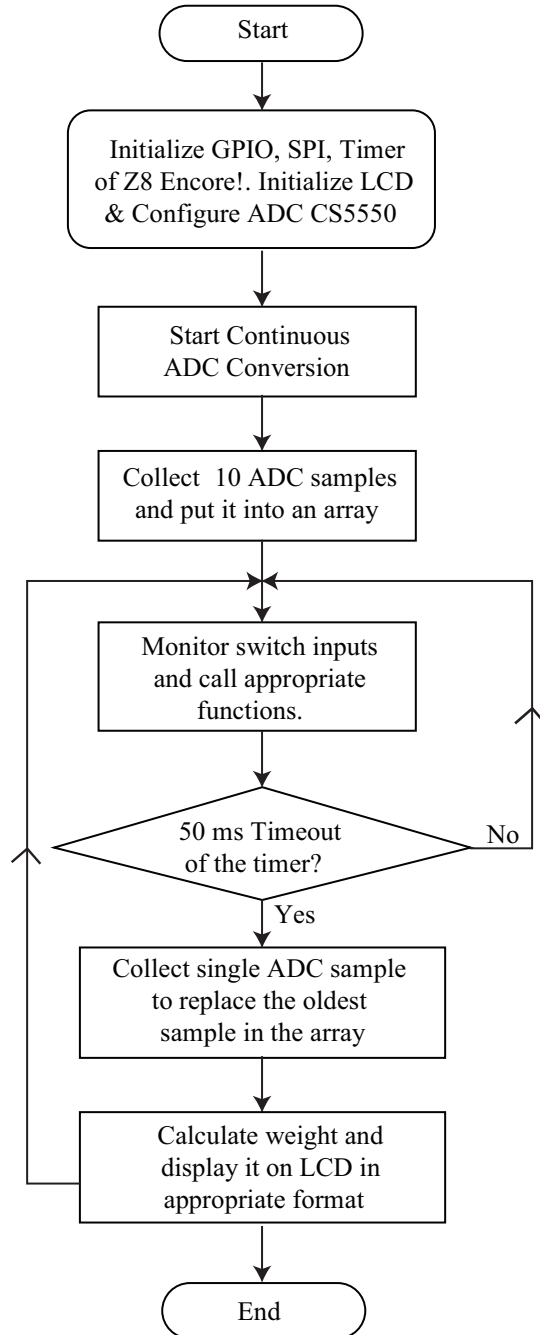

Figure 4. Main Function

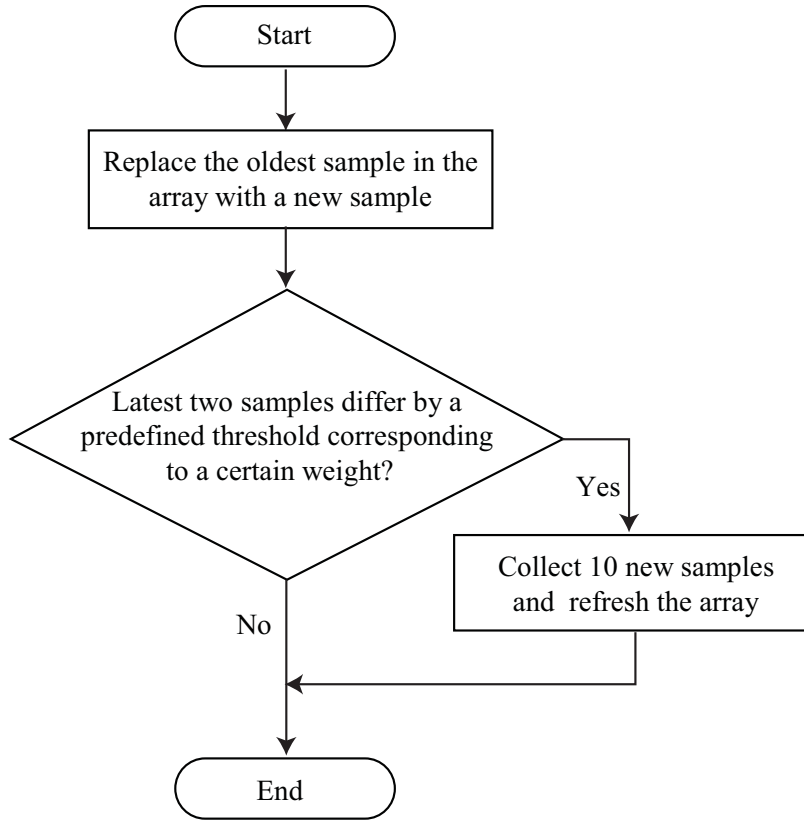

Figure 5. ADC Sample Collection and Change in Weight Detection Routine

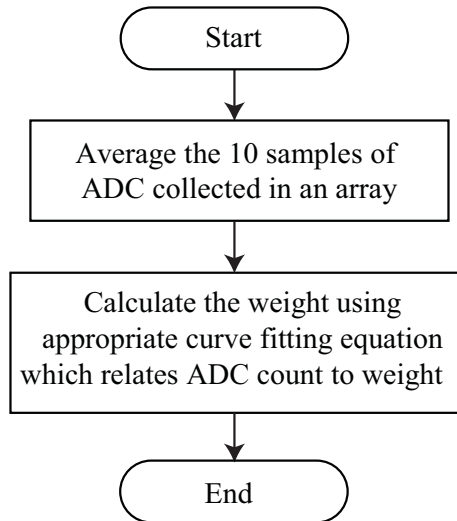

Figure 6. Weight Calculation Routine

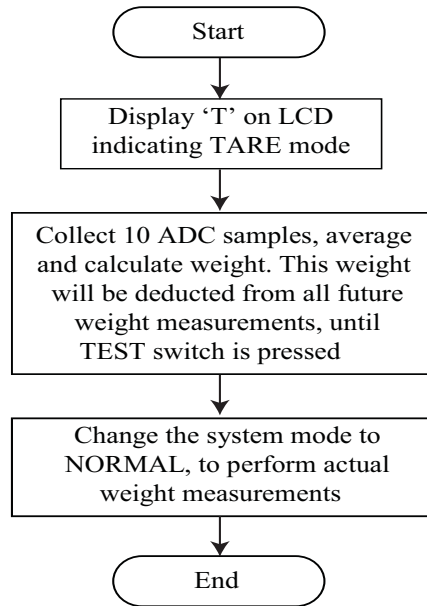

Figure 7. TARE Switch Handling Function

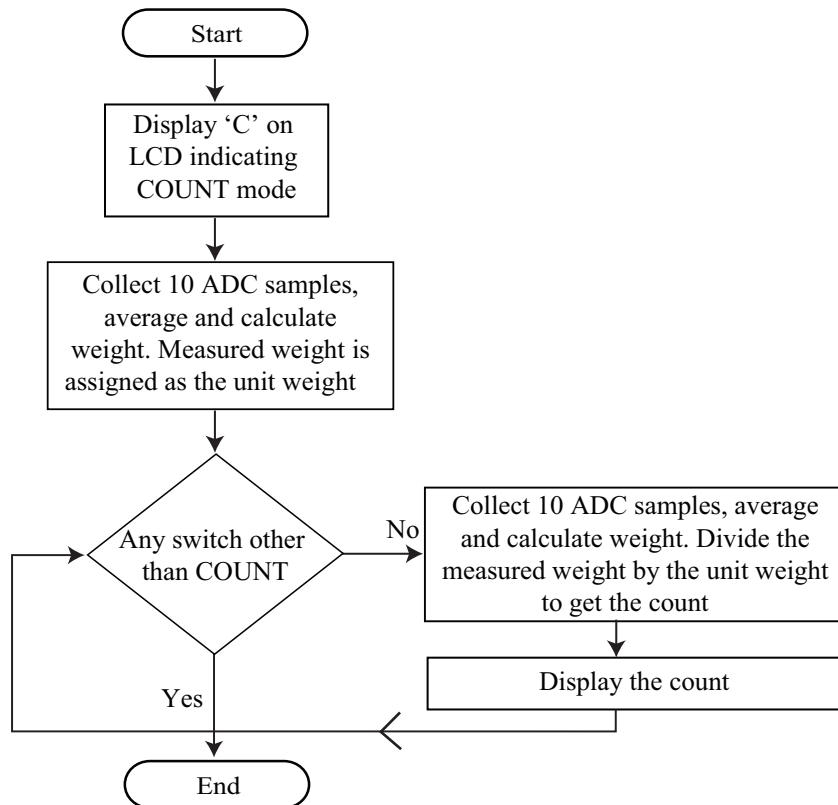

Figure 8. COUNT Switch Handling Function

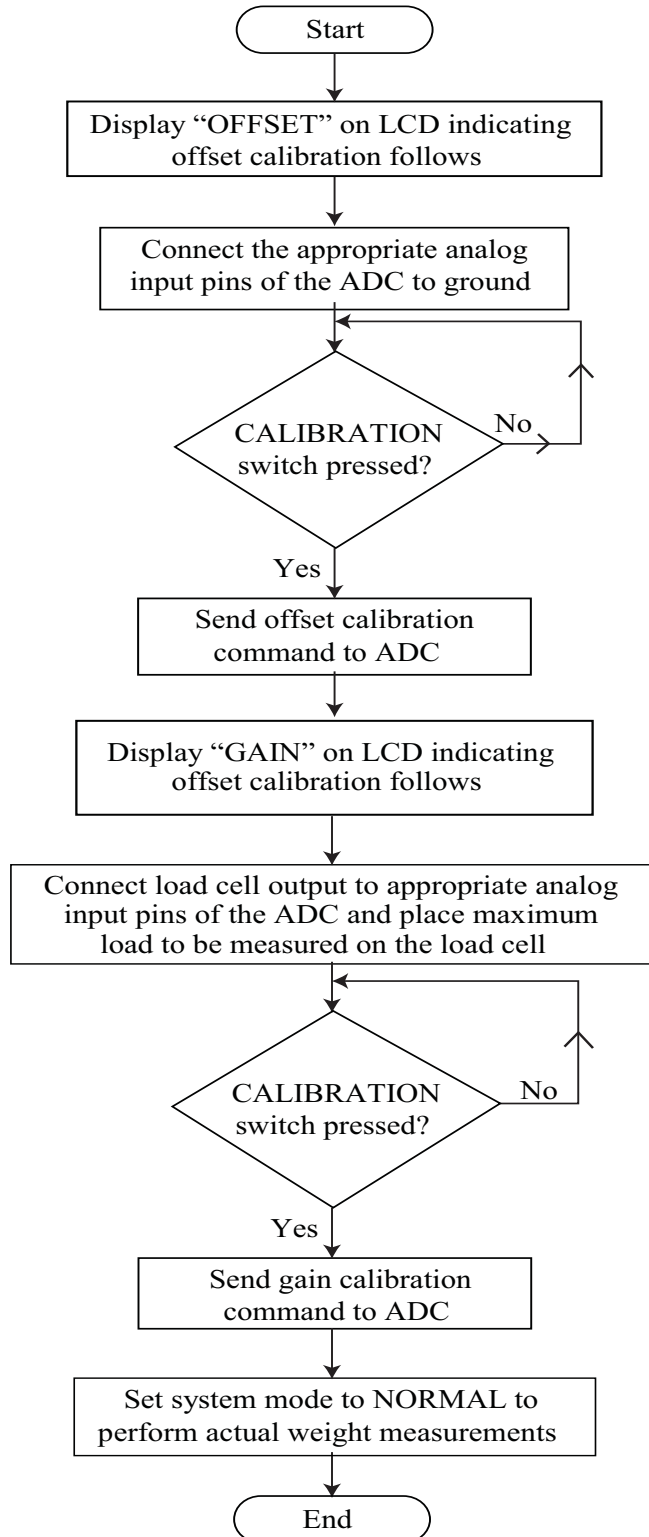

Figure 9. CALIBRATION Switch Handling Function

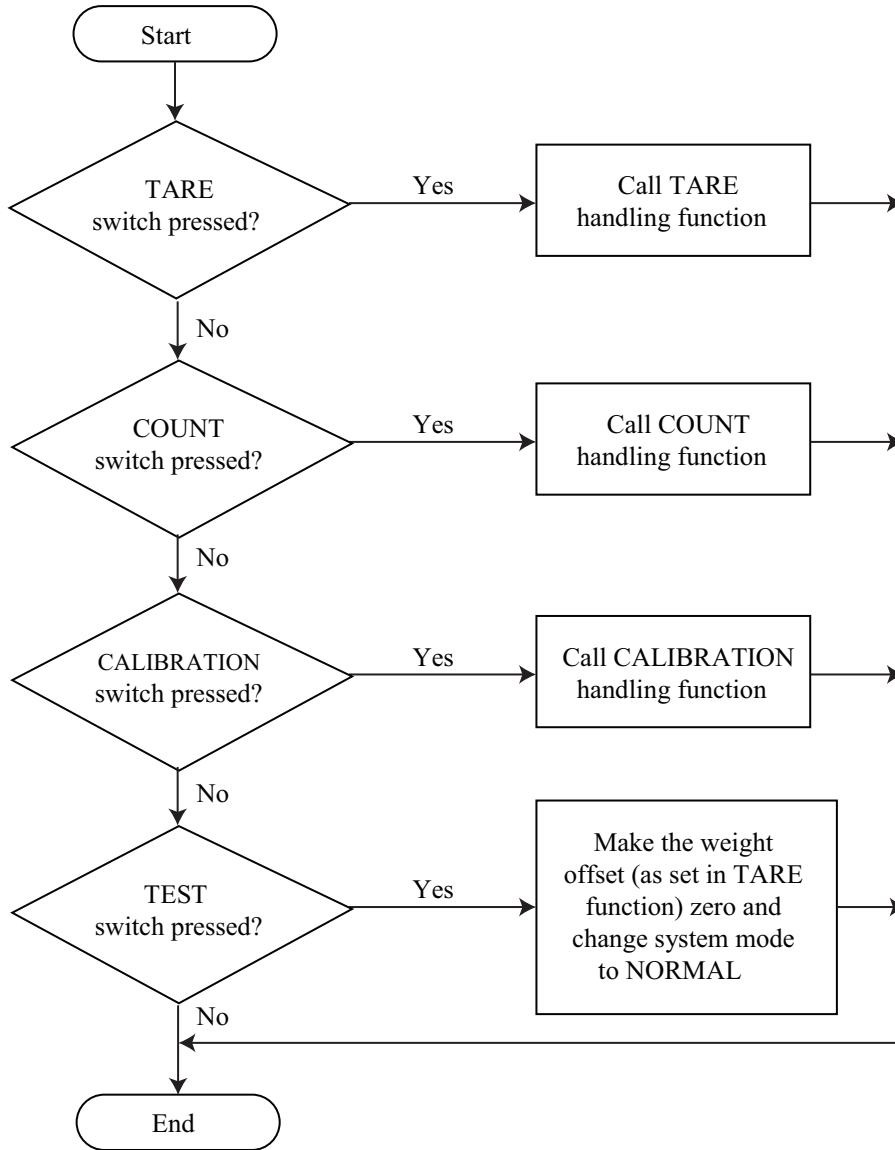

Figure 10. Processing Switch Inputs



This publication is subject to replacement by a later edition. To determine whether a later edition exists, or to request copies of publications, visit www.zilog.com

Feedback

For any comments, detail technical questions, or reporting problems, please visit ZiLOG's Technical Support at <http://support.zilog.com>

Information Integrity

The information contained within this document has been verified according to the general principles of electrical and mechanical engineering. Any source code associated with this document available in Application Sample Libraries on www.zilog.com is written by an authorized ZiLOG employee or a licensed consultant. Permission to use these codes in any form, besides the intended application, must be approved through a license agreement between both parties. ZiLOG will not be responsible for any code(s) used beyond the intended application. Contact the local ZiLOG Sales Office to obtain necessary license agreements.

Document Disclaimer

©2007 by ZiLOG, Inc. All rights reserved. Information in this publication concerning the devices, applications, or technology described is intended to suggest possible uses and may be superseded. ZiLOG, INC. DOES NOT ASSUME LIABILITY FOR OR PROVIDE A REPRESENTATION OF ACCURACY OF THE INFORMATION, DEVICES, OR TECHNOLOGY DESCRIBED IN THIS DOCUMENT. ZiLOG ALSO DOES NOT ASSUME LIABILITY FOR INTELLECTUAL PROPERTY INFRINGEMENT RELATED IN ANY MANNER TO USE OF INFORMATION, DEVICES, OR TECHNOLOGY DESCRIBED HEREIN OR OTHERWISE. Except with the express written approval ZiLOG, use of information, devices, or technology as critical components of life support systems is not authorized. No licenses or other rights are conveyed, implicitly or otherwise, by this document under any intellectual property rights.

ZiLOG is a registered trademark of ZiLOG Inc. in the United States and in other countries. Z8, Z8 Encore!, and Z8 Encore! XP are registered trademarks of ZiLOG, Inc. All other product or service names are the property of their respective owners.

Version Disclaimer

Application Notes are tested with the version of ZDS II available at the time of release. Subsequent releases of ZDS II may require you to modify Application Note code to restore its function.